



Our energy makes yours cleaner

IMPCO Europe Technologies develops, manufactures and markets custom-made systems and products that support the use of clean burning gaseous fuels and reduce emissions from internal combustion engines to the lowest levels.

Through the years, we have become an experienced partner for Original Equipment Manufacturers (OEM's) and our distributors. Due to our strong commitment to quality, we have built an experienced team dedicated to meet our customers needs as well as producing products in accordance with the high emission standards.

Our experience and dedication to the market have made us the leader in the material handling gaseous fuel industry in Europe. IMPCO Europe Technologies is ISO 9002 certified since 1994 and more recently received the ISO 9001 : 2000 certificate in 2001.

IMPCO EUROPE Tech. BV
Distributieweg, 9
2645EG DELFGAUW
THE NETHERLANDS

T + 31 15 274 2555
F + 31 15 274 2559

WWW.IMPCO-EUROPE.COM

E & PE CONVERTER

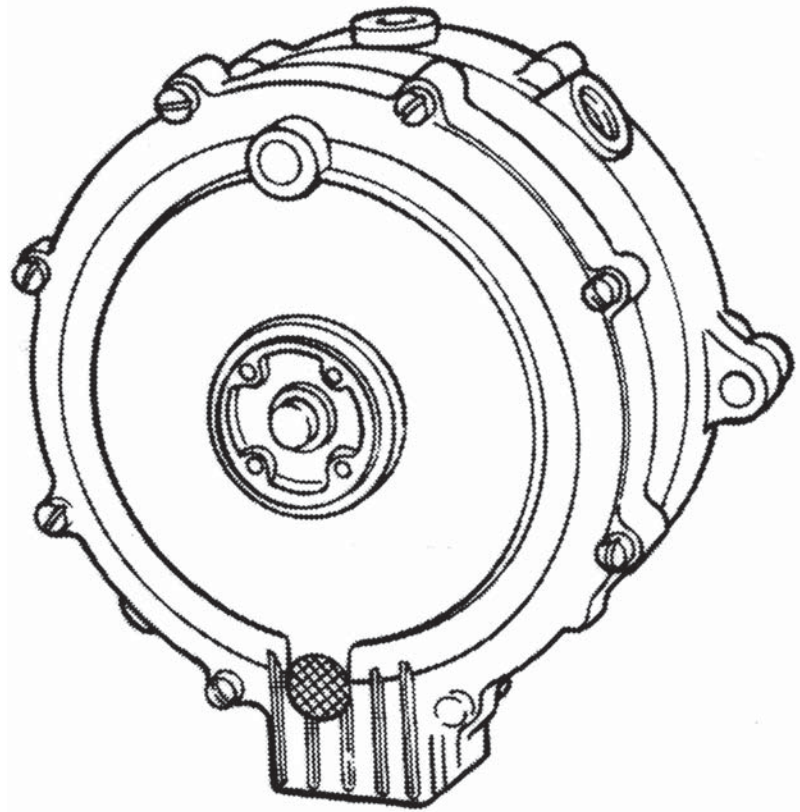

The IMPCO model E & PE series are two-stage regulators / converters. It is engine coolant heated to assist liquid fuel vaporization. Diagnostic ports are standard for both the primary and secondary pressure, and a choice of diaphragm materials is available.

The model E series provides a negative outlet pressure .

The model PE series provides a positive outlet pressure. It is offered for special applications, applications that require positive pressure like GNV applications.

TECHNICAL DATA

Fuel	LPG, GNV
Temperature range	-40C° to 121C°
Rating	until 150 kW (200hp)
Outlet pressure	E standard -1.5 w.c. PE positive 4.5 w.c.
Heating chamber source	Water, air only for GNV



E & PE Series

Repair kits

RK-E

