



Our energy makes yours cleaner

IMPCO Europe Technologies develops, manufactures and markets custom-made systems and products that support the use of clean burning gaseous fuels and reduce emissions from internal combustion engines to the lowest levels.

Through the years, we have become an experienced partner for Original Equipment Manufacturers (OEM's) and our distributors. Due to our strong commitment to quality, we have built an experienced team dedicated to meet our customers needs as well as producing products in accordance with the high emission standards.

Our experience and dedication to the market have made us the leader in the material handling gaseous fuel industry in Europe. IMPCO Europe Technologies is ISO 9002 certified since 1994 and more recently received the ISO 9001 : 2000 certificate in 2001.

IMPCO EUROPE Tech. BV
Distributieweg, 9
2645EG DELFGAUW
THE NETHERLANDS

T + 31 15 274 2555
F + 31 15 274 2559

WWW.IMPCO-EUROPE.COM



VACUUM FUELOCK FILTER VFF30

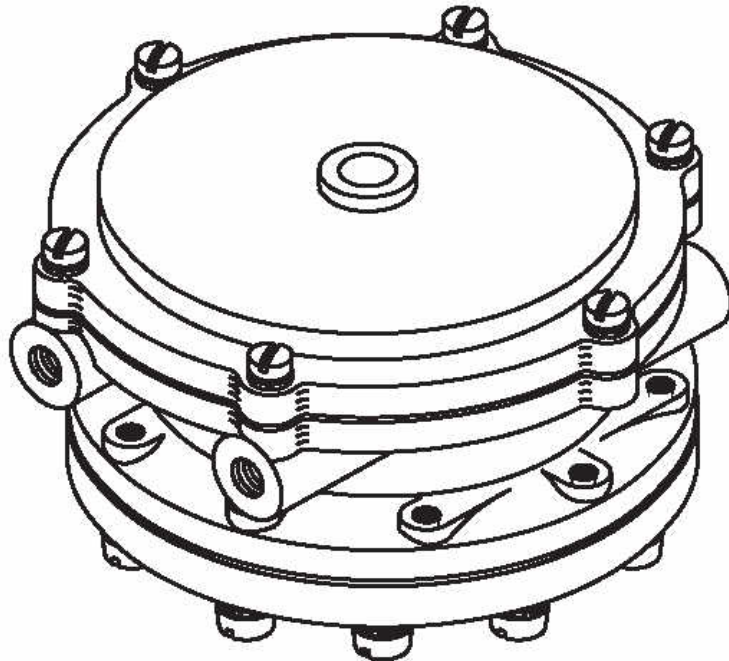

The IMPCO VFF30 is a combination fuel lockoff and filter engineered for use with LPG or natural gas.

The VFF30 is suitable for engines up to 242 kW (325hp) at a maximum working pressure 2150 kPa.

The filter element is fully service-able.

TECHNICAL DATA

Fuel	LPG or GNV
Pressure max.	2150 kPa (312 psi)
Operating range	-40C° to 121 C°
Flow rate	12.6 L/s (26.7cfm)
Power rating	242 kW (325hp)
<u>Vacuum activation</u>		
Min opening	1.69 kPa (0.5" H ₂ O)
Max opening	2.86 kPa (11.5" H ₂ O)

VFF30

Pochette réparation RK-VFF30

